

1	HR 1505	-8 SAE M x -6 JIC M	6
2	HR 4628	14' HOSE, CRIMP 1 END	6
3	HR 4716	1/4 NPT M x -6 JIC M ADAPTER	2
4	HR 4717	1/4 NPT M x -6 JIC F ADAPTER	2
5	HR 4681	-6 SAE M x -6 JIC M 90° ELL	9
6	HR 4682	-6 SAE M x -6 JIC M ADAPTER	2
7	HR 4683	-6 JIC M x -6 JIC F 90° ELL	8
8	HR 4684	-6 x -6 x -6 JIC TEE	1
9	HR 4752	36" STROKE HYDRAULIC CYLS.	2
10	HR 4585	-4 HOSE, 228" CRIMP 1 END	3
11	HR 4718	FLOW CONTROLS	2
12	H 7040-1	FLOW DIVIDER/COMBINER	1
13	HR 3504	23" STROKE MASTER CYL.	1
14	HR 4542 A	COVER CONTROL VALVE-3 SPOOL	1
15	HR 2055-12	FLOW DIVERTER	1
16	HR 2021	-8 SAE M x -8 JIC M ELL	1
17	HR 4720	-8 HOSE x 8' L, CRIMP 1 END	2
18	HR 4721	REUSEABLE FITTING FOR -8 HOSE	2
19	HR 4685	REUSEABLE FITTING FOR -4 HOSE	11
20	HR 4722	1/2 NPT M x -6 JIC M ADAPTER	3
21	HR 4562 A	-4 HOSE x 9' L, CRIMP 2 ENDS	1
22	HR 4563	-4 HOSE x 6' L, CRIMP 2 ENDS	1
23	H 7048	3/8 NPT M x -6 JIC M 90° ELL	2
24	HR 4520	GANTRY CYL. 36" STROKE	1
25	HR 4584	-4 HOSE, 192" CRIMP 1 END	2
26	HR 2057	-4 SAE M PLUG	1
27	HR 3503	23" STROKE SLAVE CYL.	1

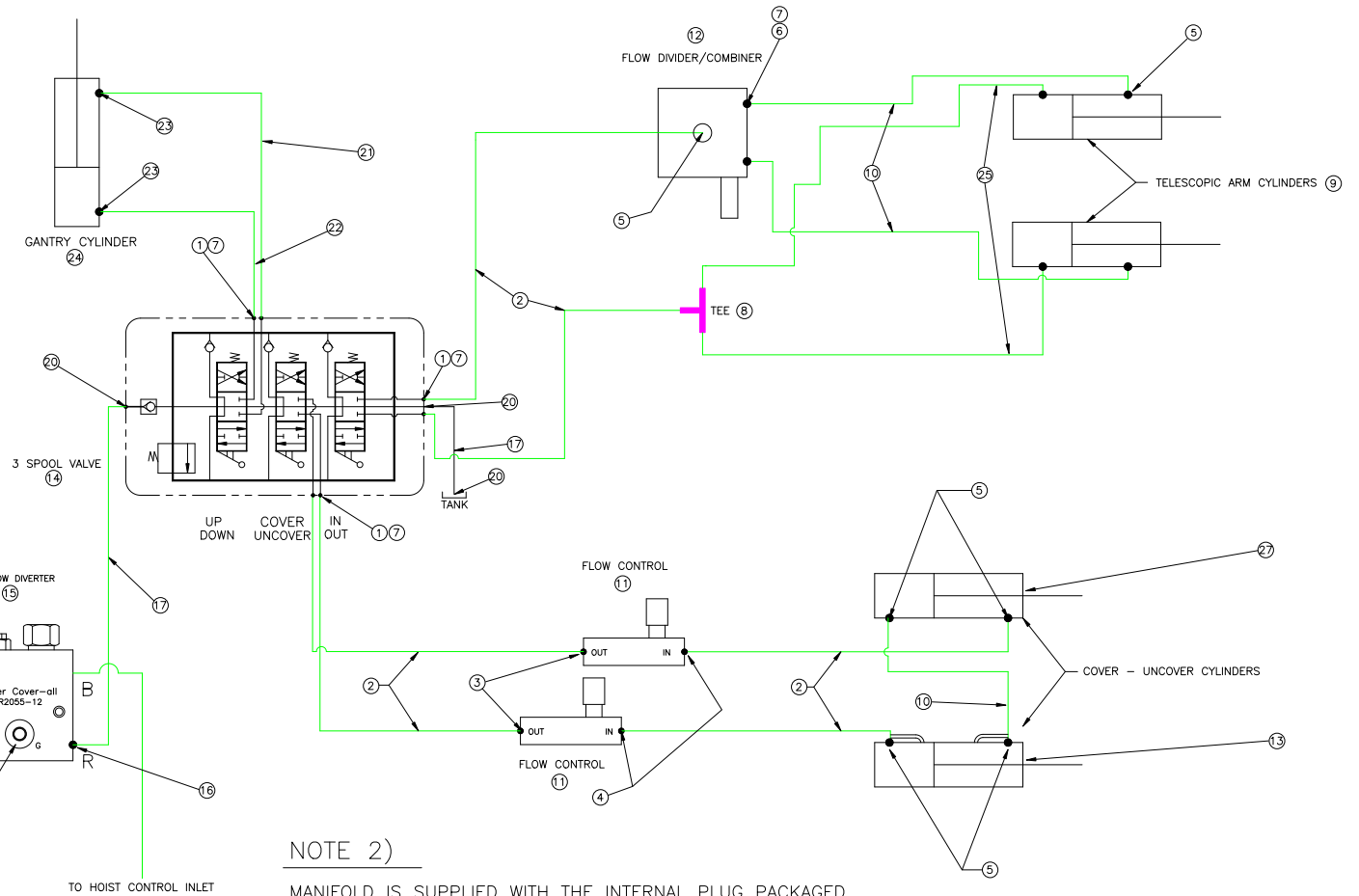

NOTE 1)

SCHEMATIC SHOWN WITH RECOMMENDED, PRV RETURN LINE BACK TO TANK. PRV BACK TO TANK MUST BE USED FOR APPLICATIONS WHERE FLOW RATES GREATER THAN 30 G.P.M. EXIST, OPTIONAL FOR LESSER FLOW RATES. REFER TO NOTE #2 FOR CONVERSION INSTRUCTIONS.

NOTE 2)

MANIFOLD IS SUPPLIED WITH THE INTERNAL PLUG PACKAGED SEPARATELY, AND THE "T" PORT PLUGGED (NO RETURN LINE BACK TO TANK). FOR MAXIMUM SYSTEM PROTECTION, PIONEER RECOMMENDS THAT THE RETURN LINE BACK TO TANK BE UTILIZED. APPLICATIONS WHERE FLOW RATES GREATER THAN 30 G.P.M. EXIST, THE RETURN LINE BACK TO TANK MUST BE EMPLOYED. TO INSTALL THE LINE BACK TO TANK:
 1) REMOVE THE DIVERTER VALVE.
 2) INSTALL THE INTERNAL PLUG THROUGH THE "B" PORT.
 3) REPLACE THE "T" PLUG WITH #16 SAE ADAPTER.
 4) REPLACE THE DIVERTER VALVE.

Pioneer Consolidated Corp.
 North Oxford, MA 01537

HYDRAULIC SCHEMATIC FOR HR3500 RG
 with GANTRY

DWG. NO. HR 3501-4	3-2-04
WHERE USED	NEXT ASSY.
SCALE: NONE	DWN. BY: R.A.T. HR3501-4