

G 500 REC

*Manual Covering System
for Recycling Containers*

CRANK 'N ROLL

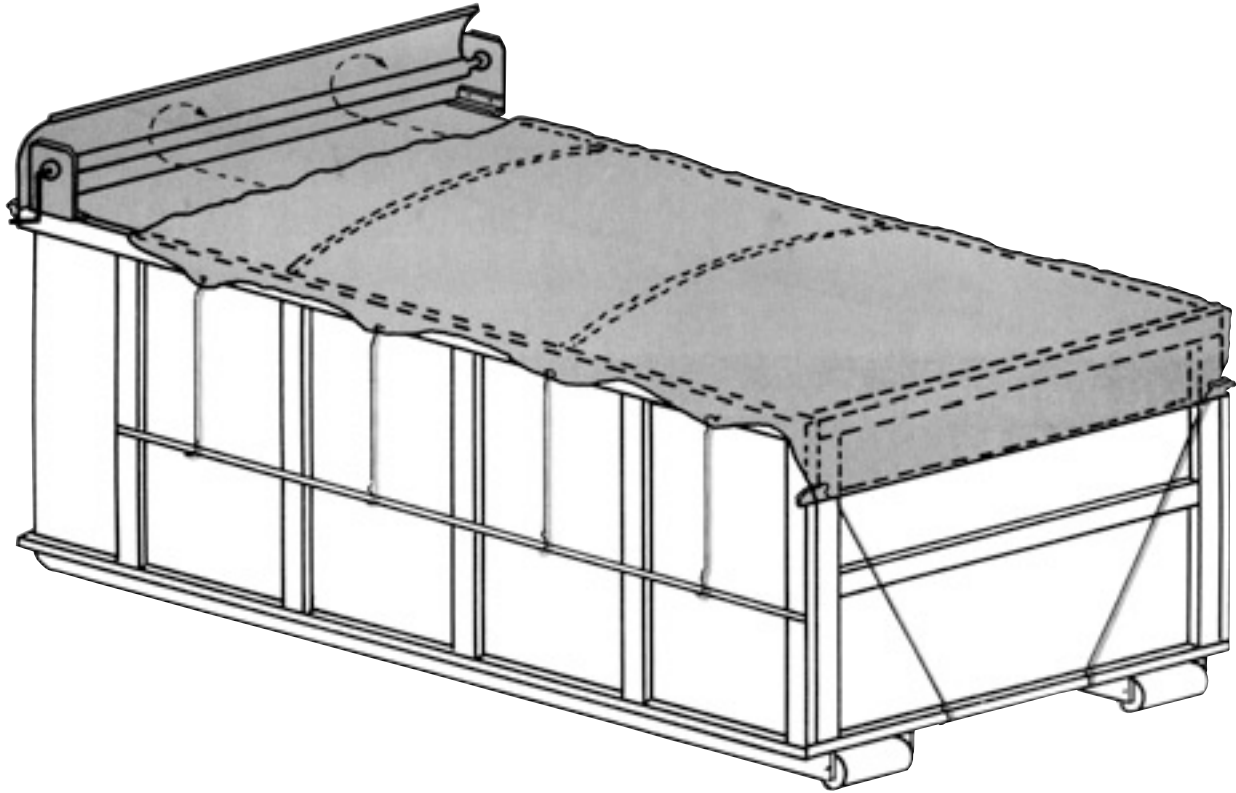

**Complete, light-weight cover for open-top containers.
Ideal for MRF and RDF facilities.**

Roller and crank assembly that mounts on the front of the container

9-ft. wide waterproof cover (18-oz. vinyl coated nylon) with built-in shock cords which allow the wider cover to be rolled up into a narrow roller.

Zinc-plated tubular steel rear section that fits through a pocket in the rear to aid in covering and uncovering.

Curved metal deflector to prevent wind from getting under the cover during transportation of container.

31-in. heavy-duty tarp straps and S hooks for securing cover to the container.

Ships UPS (2 boxes)

Optional curved bows (1 sq. steel tube).

PO Box 246 • No. Oxford, MA 01537
tel 800-237-0225 fax 508-987-1311

pioneer cover-all™
...Leading by design